





DUCATI MONSTER S2R/S4R

Item Code **Codice Articolo**
Référence Article

D/138B/IX

Part List
Lista della bulloneria
Liste des pièces

A		TBCEI 8x20	x 4
B		Ø 8	x 4
C		Ø 8	x1

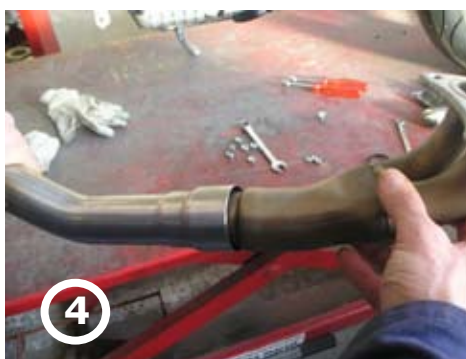
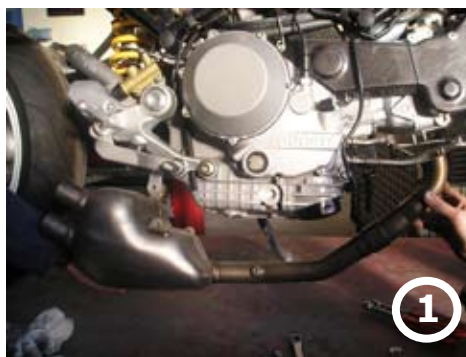



DUCATI S2R 800 / S4R

Item Code **Codice Articolo**
Référence Article

D/138B/IX

GB

CONNECTION PIPE

- 1) Remove the original manifolds and compensator paying attention to remove the original gaskets too (picture 1)
- 2) Insert the original gaskets on Marving connection pipes as shown on pictures 2 and 3
- 3) Reassemble everything starting from the front manifold and tighten all the set of bolts (pictures 4 and 5).

AFTER 500 KM CHECK AGAIN THE SET OF BOLTS AND TIGHTEN ONCE MORE IF NECESSARY

IT

TUBO RACCORDO

- 1) **Smontare i collettori ed il compensatore originale facendo attenzione a rimuovere le guarnizioni originali (foto 1)**
 - 2) **Infilare le guarnizioni originali sui raccordi Marving, facendo attenzione ad inserirle nel giusto verso come nelle foto 2 e 3.**
 - 3) **Rimontare il tutto iniziando dal collettore anteriore e serrare la bulloneria (foto 4 e 5).**
- DOPO AVER PERCORSO 500 KM RICONTROLLARE LA BULLONERIA ED EVENTUALMENTE EFFETTUARE UN SERRAGGIO DEFINITIVO.**

FR

TUBE RACCORD

- 1) *Enlever les collecteurs originales, en faisant attention à enlever aussi les joints originales (photo 1).*
 - 2) *Insérer les joints originales sûr les tubes de raccord Marving en faisant attention à les insérer par le correct vers comme dans les photos 2 et 3.*
 - 3) *Remonter tout en commençant par le collecteur antérieur et serrer la boulonnerie (photos 4 et 5)*
- APRES 500 KM RECONTROLLER LA BOULONNERIE ET SI NECESSAIRE LA SERRER ENCORE UNE FOI.*